



G-1 Voice Pager

Voice Pager for Public Safety



Please contact us with our Toll Free phone number : 888-657-2963

Leave a message on the Unication Website : <http://www.unicatlon.com> or <http://www.unicationusa.com>

Content

Part A. Company Profile **A1-1**

Part B. G1 Voice Pager Design Concept **B1-1**

Part C. G1 Voice Pager Feature **C1-1**

Part D. G1 Voice Pager Specification & **D1-1**
Function Description

■ What is Unication ?

- Unication Co., Ltd was originally founded in 1992 and has 27 years' experience with designing and manufacturing advanced critical communication solutions and systems for first responders. The innovation and advancement of Unication' s professional radio communications products is the main spindle of the brand's development.
- Unication currently has independent design centers and sales offices based in the United States (Los Angeles CA, Dallas TX, Boca Raton FL), Canada, Australia and Germany.
- Unication products are sold worldwide and currently in service in the United States, Canada, the Netherlands, Norway, Sweden, Switzerland, Australia, Italy, India, Indonesia and Middle East countries.

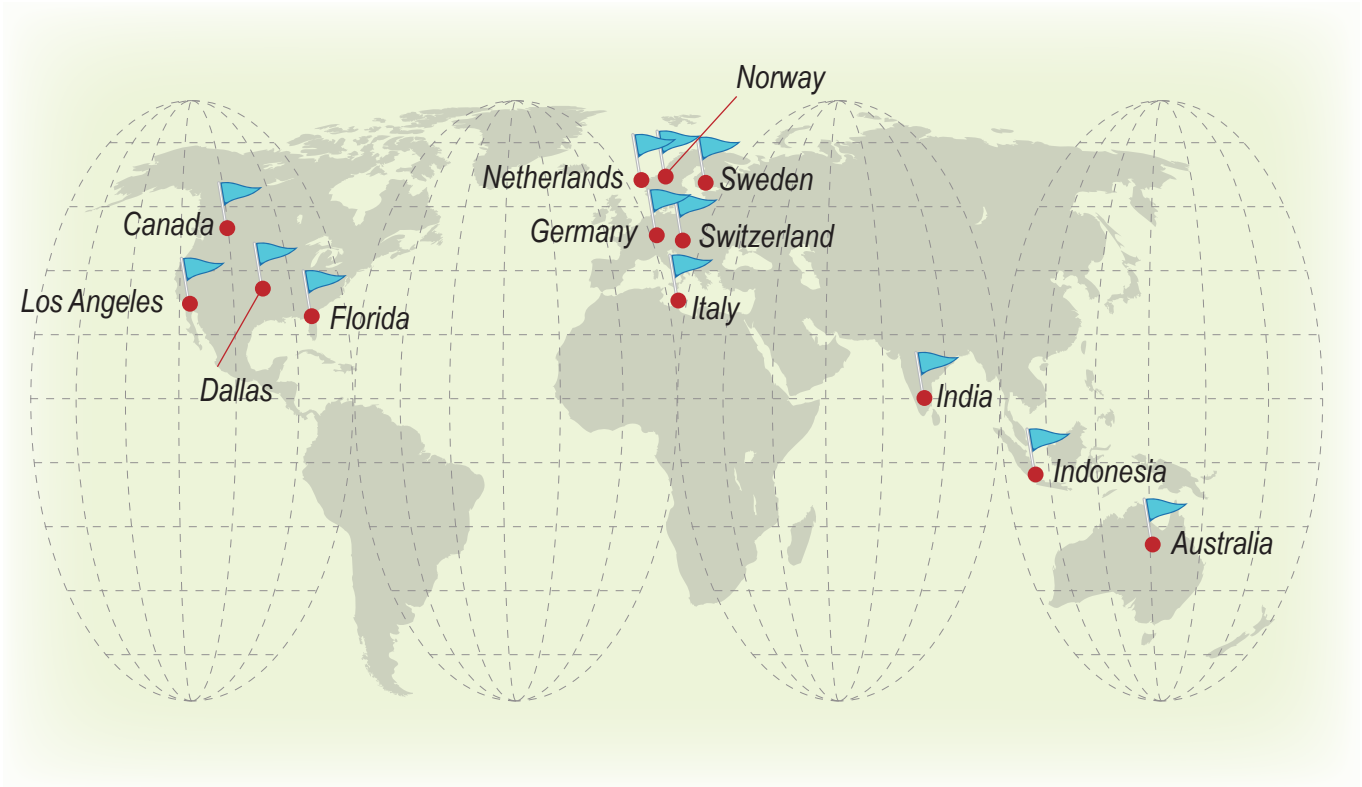

■ Unication Voice Pager Design Concept :

Utilizing voice pagers to alert volunteer firefighters of emergency incidents has been a fire department tradition for decades. From generation to generation, the unnamed heroes of volunteer fire departments have been a huge contribution to our society.

For many years, volunteer fire departments and firefighters have faced communication issues, including:

- For decades, Voice Pager receives messages in “One-Way” only, making it hard to know the usage situation of the voice pager on the volunteer firefighters. During a mission when the Dispatch Center transmits a message, it does not allow for responses from the receivers, which can cause difficulty in for dispatchers.
- In the past, Voice Pager was limited by the protocol of 2 Tone and 5/6 Tone. Therefore, it can only receive the signals transmitted by the dispatch center causing the volunteer firefighters to not receive important on-site information (e.g. building usage scenario, building materials, details on any dangerous goods in the building, etc.). This lack of information can put volunteer firefighters in danger. Generally, the rescue personnel to first arrive on scene will use the radio system to communicate with each other and exchange the key message. It is very important to volunteer firefighters if they can listen to these on-site transmissions, to better understand the position of the accident and have access to these key messages on the way to the emergency scene.
- In the past, Voice Pagers did not have a screen and the only information received is the audio message. This limits the ability to receive all messages (voice message and text message) transmitted by the Dispatch Center. When a volunteer firefighter cannot access sufficient information for the rescue; it causes difficulty in arranging the manpower, dispatching personnel and can even affect safety of the personnel.

Unication has been dedicated to developing radio systems for 25 years. In the past, Unication designed and manufactured M3, M4, and M5 voice pagers. We have over 20 years of experience designing voice pagers and have worked hard to implement the features that customers demand. Unication incorporates many features not found in a conventional pager into the G1 Voice Pager with the goal of improving efficiency of Dispatch, more effectively handling disaster relief and rescue incidents, and most of all ensuring the safety of volunteer firefighters and first responders.



■ Unication G Series Voice Pager Feature :

● Supports Multiple Communication Protocols and Dispatch Systems.

- The Unication G1 Voice Pager supports the most protocols in the market, including 2 tone / 5 tone / MDC communication protocol demodulation, in addition to supporting CTCSS and CDCSS. The G1 can receive system messages from Repeater and different Voice Paging Systems. The various features of the Two-Way Radio have been merged with the G1 and combined with the current Radio System to send the message and allow users to receive disaster relief site information from various dispatch systems.

● Supports Voice Message & Text Message for clear and complete mission assignment information.

- The G1 Voice Pager has an added MDC1200 text message receiving function allowing the Voice Pager to receive not only voice messages but text messages as well. Dispatchers can relay important details and assignment locations by text message allowing responders to receive clear and complete assignment information.
- Supports Voice Message: 2 Tone/ 5 Tone allows the user to receive the message in the communication way mentioned above and it supports up to 17 minutes length voice message recording.
- Supports Text Message: It supports sending MDC1200 text messages via Radio System.

● Display Channel Setting Information on LCD Monitor:

- The G1 Voice Pagers LCD monitor displays the current channel information and channel name, allowing the user to access pager status in standby mode. Users may view the receiving mode, frequency & talk group and see transmitter information, messages, signal strength, battery power, date & time and so on. Users have no need to copy any frequency table, as the information can be viewed on the pager screen.
- Users can easily listen to a saved message, without having to play back all messages, by selecting the voice message from the LCD monitor of the pager. Users may also select and view the preset ACK canned message to be sent and manage/ delete/ retain the read message content.
- The G1 LCD screen offers users an interface to change settings, so instead of going into the programming on the PPS software, users may adjust pager settings such as the receiving alert mode, receiving table, scan list, Bluetooth, Duty On/Off and so on through the pagers menu.
- Seven backlight colors and 12 groups of alarms can be assigned to different message sources or groups according to the settings of the receiving table. It is convenient for users to use the alarms and LCD backlight colors to immediately identify the sender and the emergency level of the message and source.

● Supports Scanning Function to Automatically Enable Speaker to Play the Voice Message

- If the user wants to temporarily monitor messages that are not in the preset channel list or use G1 as a scanner, the user can set G1 to select the single channel Monitor mode for scanning reception. If there is a message at the current frequency when scanning, G1 will automatically turn on the speaker to play the message. After the message is sent, G1 will automatically turn off the speaker and continue scanning the list.

● Prevents Cellular Phone Interference- Do Not Miss Important Messages:

- Today, everyone has a cellular phone. In the past, the power of the mobile phone could affect the pager's message reception and cause it to miss the message. G1 takes special precautions against the interference of mobile phones so that you can safely hang them side by side without missing any important messages.

● Support Bluetooth Function:

- The user monitors the voice message. It can be connected when the message needs to be kept confidential or the receiving environment is noisy.
- Listen to clearer messages wirelessly.
- When receiving the voice messages, make it audible only to yourself and not to others.
- It can be connected to a mobile phone and use the Unication APP to reply ACK to the PS & DRT Console to facilitate the dispatch center to perform dispatching work.

● Supports Various Battery Types:

- In addition to providing eco-friendly rechargeable batteries, G1 can also choose to use ordinary disposable alkaline batteries. Users can place the pager on the charging base to charge it regularly, eliminating the need to purchase and replace the new batteries. When it is used for a long time but cannot be charged, the user can also replace the disposable alkaline AAA type batteries at any time. In any environment, you do not need to worry about the problem of insufficient battery power and unable to turn on G1.

● Ability to Automatically Open Duty Settings According to Your Weekly Plans:

- If you do not want to be disturbed by the message notification sound during the non-duty hours, but do not want to miss every message, we recommend that you set the Duty On / Off mode to solve your problem.
- The factory setting of G1 Duty On / Off function is Duty On. When in the Duty On mode, all the received messages will have a message alert. If you set G1 to Duty Off in Duty On / Off mode, G1 receives the message. At that time, only the recording archive work will be performed, and no message notification sound will be sent to remind you.
- G1 provides you with the Duty On / Off switching method to avoid your troubles. In the past, Duty On / Off can only be distinguished according to channel. Sometimes forgetting to switch Duty On / Off causes the device to yell at work. G1 can adjust duty status manually and use the Duty On / Off function menu of Pager setting to switch.
- The user can also preset the automatic power on / off function. The automatic power on / off time can be set on the same day, the purpose is to automatically shut down when off duty, to achieve the power saving effect.

● Support Personal Assistant Functions Such As Voice Memo and Alarm:

- The G1 supports voice memo and alarm functions. The Voice Pager can be used as a personal assistant, which is convenient for users to record daily things or important message memos. The G1 supports 8 minutes of voice memos.
- Use Today Function to Read Things Quickly:
 1. Unread Voice / Text Message.
 2. Message without ACK Back.
 3. If the user presets the message alarm, and when the message is not read, there will be a message alarm prompt.

● PS and DRT Can Support OTAP and OTAC Functions:

- G1 Voice Pager supports OTAP function. Dispatch center can also use OTAP function to target single or group users directly in the air. Pager performs multiple function settings and switching, such as: Receiving Channel, ACK Function, ACK Phone No, ACK GPRS IP / Port, Emergency Call Phone No., Pager Time, etc.; eliminating the trouble of recalling the pager one by one for setting. Save your time!
- G1 Voice Pager also supports multiple OTAC functions. The dispatch center can also use the OTAC function to directly control multiple functions for a single or group pager user in the air:
 1. Pager Disable / Enable Function: When G1 Pager is lost or otherwise and you need to stop the operation of this pager, you can notify the dispatch center. The dispatch center can send the pager disable OTAC command through the Uni Voice Pager Console to shut down the pager's operation functions and stay in a specific channel. Until you get your G1 back, the dispatch center can send pager enable OTAC command again, enable pager's function, and resume normal operation.
 2. Pager Check Function: Pager Check Function can assist the dispatch center to check the communication status of G1 to see if the G1 that you are carrying is in a communicable state; send the Pager Check command through the Uni Voice Pager Console. After receiving the message, G1 responds with an ACK to let the dispatches center will know if the pager is in the signal cover range.
 3. Switch Off Duty to On Duty: When the dispatch center sends out a message, the receiving and replying status of the pagers are not good or need more manpower, the dispatch center can use this function to change the pager current mode from Duty Off to Duty On. Then send a message again so that more users can receive rescue messages.

■ ■ Unication Voice Pager Specification & Function Description :

● G1 Voice Pager Overview :

● Top View

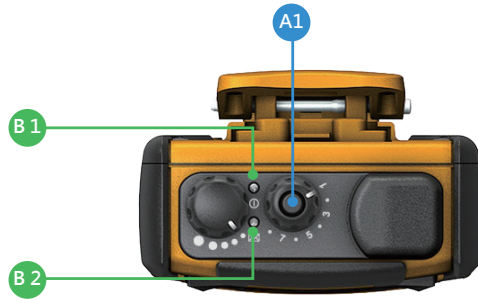

● Left Side View

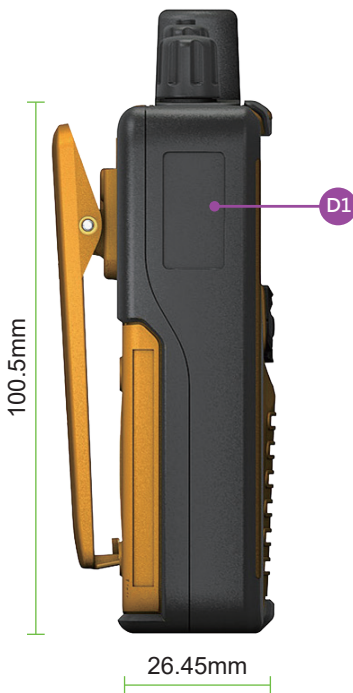

● Front View



● Right Side View

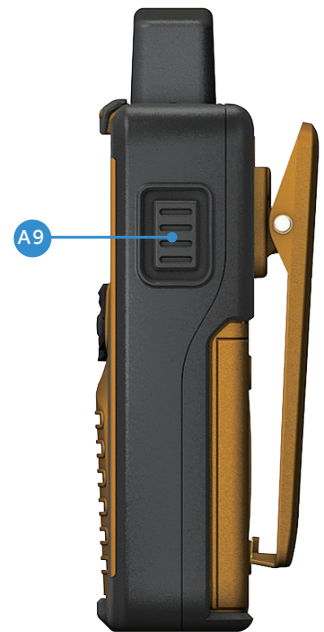

A : Button			
A1	Play Key	A6	Navigation Key
A2	Switch / Volume Knob	A7	Function List Key
A3	Function Switch Knob	A8	Read Key
A4	Function Key	A9	Reset Key
A5	Record Key		

B : LED Indicator	
B1	Power / Charging Indicator
B2	Message Indicator

D : Others	
D1	Name Sticker

C : LCD Screen	
C1	LCD

E : Sensor	
E1	Microphone

PART D. G1 Voice Pager Specification & Function Description

Voice Pager Series		G1			
Product Model of Voice Pager Series		Low Band	VHF	UHF	
A Frequency and Mode of Device					
A1	Frequency Range	Loop Antenna	33 - 49MHz 66 - 88MHz	137 - 174MHz	406 - 512MHz
A2	The Setting of the Receiving Band Width (kHz)		12.5kHz 25kHz 20kHz	12.5kHz 25kHz 20kHz	12.5kHz 25kHz 20kHz
A3	Signal mode can be received	Use the analog signal.	●	●	●
A4	Message type can be received	Use for the 2 Tone voice message, 5/6 Tone voice message, MDC1200 voice message, MDC1200 text message, 2 Tone + MDC1200 voice message, 2 Tone + MDC1200 text message, and CDCSS / CTCSS voice message. Support GSM / GPRS / Bluetooth 4.0 ACK function	●	●	●
B Operational Environment of Device					
B1	Operational Environment of Radio Device	● Range of Operating Temperature	-10 ~ +50 °C	-10 ~ +50 °C	-10 ~ +50 °C
B2	Operational Environment of LCD Screen	● Range of Operating Temperature			
B3	Operational Environment of Battery	● Range of Operating Temperature	-10 ~ +50 °C	-10 ~ +50 °C	-10 ~ +50 °C
B4	Waterproof Condition of the Equipment	●The sample is placed in the immersion tank and the distance from the bottom of the sample to the water surface is at least 1 m. The distance from the top of the specimen to the water surface is at least 0.15 m. Test time: 30 min.	IP X7	IP X7	IP X7
B5	Dustproof Condition of the Equipment	●No ingress of dust under the low pressure of 20 mbar	IP 6X	IP 6X	IP 6X
B6	Explosion-Proof of the equipment	●UL	Class I, Division 2, Groups A, B, C and D Class II, Division 2, Groups F and G Hazardous Locations		
B7	Against Fall Condition of the Equipment	● Fall from the height 1.8m. Test for all sides of the prototype.	●	●	●
B8	Safety Certification of the Equipment	●FCC / CE / RoHS / BOS / MIL-STD 810E	●	●	●
C Hardware Specifications of Equipment					
C1	Appearance of Device		Please refer to page 5		
C1	Dimensions (Without antenna / With protection sheet)	Height (H) (mm)	100.5mm	100.5mm	100.5mm
		Width (W) (mm)	65.2mm	65.2mm	65.2mm
		Thick (T) (mm)	26.45mm	26.45mm	26.45mm
C3	Texture		PC14312 (Plastic) +TDV (Rubber)		
C4	Weight (Without antenna and battery)		220g	220g	220g

Voice Pager Series		G1		
Product Model of Voice Pager Series		Low Band	VHF	UHF
C Hardware Specifications of Equipment				
C5 Specification of Screen		128x48 single color		
C6 Specification of Battery (Standard Accessory)	AAA / UM - 4 Ni-MH rechargeable battery AAA / UM - 4 Alkaline battery Capacity = 680 mAh @ Ni-MH rechargeable battery Capacity = 800 mAh @ Alkaline battery Max. Voltage = 2.88V @ Ni-MH rechargeable battery Max. Voltage = 3.30V @ Alkaline battery	●	●	●
	Normal Voltage Supply = 2.4V @ Ni-MH rechargeable battery	2.4V	2.4V	2.4V
	Normal Voltage Supply = 3.0V @ Alkaline battery	3.0V	3.0V	3.0V
	The battery usage of this model is calculated in accordance with international conventions. Standby: Received = 90:10	Two-Tone 72hrs	Two-Tone 72hrs	Two-Tone 72hrs
C7 Hardware of user's operating interface	Power Switch and Volume Knob	●	●	●
	Channel Knob *1 Switching of 8 channels in one zone Provide the 8 receiving zone for users to set. 8 receiving tables of 2/5-Tone 8 receiving tables of MDC1200 Each receiving table contains 16 addresses the most.	●	●	●
	Quick button for the voice record play. a. When the user presses the button, it will activate the voice recording playing function. It will start playing from the latest recording and play a tone alert in the recording end to remind the user, then continuously play the next recording until all the recordings are played. b. Press the button during the process of the recording playing, it will stop the current recording and play the next recording.	●	●	●
	4-direction button (Up, Down, Left, Right) and confirmed button a. For the user shift the cursor on the screen and select the option.	●	●	●
	Four dynamic function buttons It does not support the dynamic function buttons when the screen standbys. Use "←" "→" to shift the cursor. Use Menu key to operate the Soft Key function. a. It will dynamically assign four corresponding function items b. Press the "→" (blank) can switch into the second page.	●	●	●
	FA Main Menu Key to quickly show the main function menu. a. Since there are multiple setting functions and several levels for each setting, this button helps the user can quickly alter the screen into the menu.	●	●	●

PART D. G1 Voice Pager Specification & Function Description

Voice Pager Series		G1		
Product Model of Voice Pager Series		Low Band	VHF	UHF
C Hardware Specifications of Equipment				
C7	Hardware of user's operating interface			
	<p>A Back Key to shut down the currently using function and back to the last operational screen.</p> <p>a. Most of the function activation requires multiple operating screens of extracting parameters. The back key enables the user to back to previous screens of extracting parameters.</p> <p>b. When the function operating ends, the user can not only wait for the hang time and auto-back to the previous operating screen, but also manually press the back key to back to the previous screen.</p> <p>c. If the users would like to cancel the current function which is operating, they can press the back key to terminate and back to the previous operating screen.</p>	●	●	●
	<p>Quick button for quickly activate Voice Recording</p> <p>a. This button helps the user can more quickly activate the voice recording function.</p> <p>b. Press this button in the normal situation, the pager will immediately activate the Voice Memo function to start recording and turn on the speaker for recording the surrounding voice. (Press once to start recording, then press again to stop recording and auto-save the recording).</p>	●	●	●
	<p>A Reset Key for the speaker on/off and the receiving mode switch</p> <p>a. To switch on/off the speaker during the receiving status, press once to switch off the speaker, and keep pressing to switch on the speaker.</p> <p>b. When the Push To Listen function is operated, the speaker will be turned on only by pressing the Reset Key.</p> <p>c. Switching current receiving mode with the operation of the Trunking Reset receiving mode.</p>	●	●	●
D Performance and Specifications of Voice Pager				
D1	Receiving (Channel) Bandwidth of This Product Model can be set	12.5kHz 25kHz 20kHz	12.5kHz 25kHz 20kHz	12.5kHz 25kHz 20kHz
D2	Amounts of frequency can be set in this model	Amounts of frequency can be set depends on the programmed bandwidth. Amounts of frequency = Bandwidth ÷ programmed bandwidth		
D3	RF Performance	Sensitivity # TIA Standard (12dB SINAD / 5% BER)	4.0 μV/m @25kHz/20kHz 7.0 μV/m @12.5kHz	4.0 μV/m @25kHz/20kHz 7.0 μV/m @12.5kHz
		Frequency Stability	+ / - 5 ppm	+ / - 5 ppm

Voice Pager Series		G1		
Product Model of Voice Pager Series		Low Band	VHF	UHF
D Performance and Specifications of Voice Pager				
D3 RF Performance	Intermodulation Rejection	> 70 dB @25kHz > 65 dB @12.5kHz	> 70 dB @25kHz > 65 dB @12.5kHz	> 70 dB @25kHz > 65 dB @12.5kHz
	Spurious	> 70 dB @25kHz > 65 dB @12.5kHz	> 70 dB @25kHz > 65 dB @12.5kHz	> 70 dB @25kHz > 65 dB @12.5kHz
	Image Rejection	> 70 dB @25kHz > 65 dB @12.5kHz	> 70 dB @25kHz > 65 dB @12.5kHz	> 70 dB @25kHz > 65 dB @12.5kHz
	Audio Distortion	< 4 % (Electrical) / < 5 % (Acoustic)	< 4 % (Electrical) / < 5 % (Acoustic)	< 4 % (Electrical) / < 5 % (Acoustic)
	Speech SPL (at 12 inches)	94 dB SPL	94 dB SPL	94 dB SPL
	Alert SPL (at 12 inches)	96 dB SPL	96 dB SPL	96 dB SPL
E Functions of Voice Pager				
E1 Numerous certificated protocols can be selected	1. Protocol supported by Analog system a. CTCSS / CDCSS b. 2 Tones / 5 Tones c. MDC 1200	●	●	●
E2 Analog signal	Only analog signal is allowed.	●	●	●
E3 Voice / Text Reception	Only receive Two-Tone voice message, 5/6-Tone voice message, MDC1200 voice message, Two-Tone + MDC1200 voice message, Two-Tone + MDC1200 text message, CDCSS / CTCSS voice message under the analog signal. Also, GPRS / Bluetooth 4.0 ACK is supported.	●	●	●
E4 Receiving Table Setting of Diverse Receiving Modes	128 receiving table settings are available, and every receiving table (channel) can be set individually. Operation system can be set as: a. Talk Around Mode	●	●	●
	Receiving Mode Settings : a. When there is the operation system of a specific channel set as Conventional or Talk Around Mode, it can be set as the following receiving mode : a1. Multiple reception groups in singular frequency a2. Multi-frequencies scanned by the main frequency and minor one. (Assign a frequency as main frequency, and the others are minor. Scan the frequency in the following sequence: Main → Minor 1 → Main → Minor 2...) a3. Multi-frequencies scanned without main frequency or minor frequency. b. Settings of frequency and bandwidth listened (scanned). (Only programmable by PPS)	●	●	●
	c. Settings of protocol used whilst listening (scanning) frequency. (Protocols used by digital or analog system are available. Settings of listening groups are already set in the device.)	Support Analog system only.	Support Analog system only.	Support Analog system only.

PART D. G1 Voice Pager Specification & Function Description

Voice Pager Series			G1		
Product Model of Voice Pager Series			Low Band	VHF	UHF
E Functions of Voice Pager					
E4	Receiving Table Setting of Diverse Receiving Modes	d. Several groups which need to be listened for every frequency listened. However, there is no need for the protocol which is set for the analog system to program receiving groups if the protocol is for a specific protocol since it cannot be distinguished.	Support Analog system only.	Support Analog system only.	Support Analog system only.
		When a specific channel set as scanner in the working system settings, changing and setting of frequency band scan (initial and terminated frequency), interval of frequency scan, multiple scanning frequency, stay time as well as Note1: It will use the auto-detect and auto-intermodulation to check the signal mode and protocol. Note 2: Manual frequency adjustment is available to provide superior voice quality.	Only programmable in the PPS.	Only programmable in the PPS.	Only programmable in the PPS.
E5	Handheld Radio Type of Operating Interface	1. Navigation Keys and Enter key 2. Dynamic function keys are not supported when Standby mode on. Only 4 soft keys are supported in the function menu, use the right and left buttons to move the cursor (Highlight), use Menu key to operate the Soft Key. 3. Menu Key	●	●	●
E6	Voice Call Recording	1. Automatically record while receiving voice message. 2. Users will be notified of the recording status of the current voice call by icons and time on the UI while recording. 3. Every call will be a record file while recording, (Note: The so-called "Every call" includes the call of the receiving groups within the Hang Time.) and the record file will be named by the time of that call, then saved in the "Voice Call Record Box" . 4. Users can enter from the UI and play the chosen record file or the file by time period.	●	●	●
E7	Unread Message Alert	1. When the text, image or call alert is transmitted, although the pager will alert, the user might not be aware of the message due to the noisy environment. 2. The pager will alert and the indication light will flash regularly to remind users of the unread messages.	●	●	●
E8	Out of Range Alert When the device is out of the signal coverage	1. Since there would be areas could not receive the signal even the radio' s base stations have been built. Therefore, when the pager carrier is outside the signal coverage of the base station, the pager will alert regularly, and the OOR status will be indicated on the screen to remind the users.	Yes (Uni PS&DRT needed)	Yes (Uni PS&DRT needed)	Yes (Uni PS&DRT needed)

Voice Pager Series			G1		
Product Model of Voice Pager Series			Low Band	VHF	UHF
E Functions of Voice Pager					
E8	Out of Range Alert When the device is out of the signal coverage	2. Users can manually change or terminate this function by the function menu. Note 1: Users can decide whether this function can be manually enabled or disabled in the function menu.	Only programmable in the PPS.	Only programmable in the PPS.	Only programmable in the PPS.
E9	(Universal Alert)	1. Users can rapidly switch the alert mode according to the current occasion. (E.g. in an important meeting which is not allowed audible alerts.) 2. There are 4 types of alert modes: Tone, Vibrate, Silent and Tone & Vibrate. When users switch to Vibrate mode and Silent mode, the voice message of the new call will not be played out but will alert only.	●	●	●
E10	(Duty ON / OFF)	Support manual switching Duty On/ Off.	●	●	●
E11	Forward ACK Message to PS&DRT System by connecting with BT 4.0 module and user's Smartphone	1. Traditional Voice Pager is a kind of one-way receiving device, so Dispatch has no way to know how many personnel have actually received the message they have sent, and also calculate how many personnel are able to join the mission. Therefore, Unication provides this ACK forwarding function. 2. Users can pre-set the item list of the canned message for manual ACK, so users can choose the wanted canned message as Receive ACK message after receiving messages, and it will be forwarded to the PS&DRT system via BT 4.0 module as well as the internet of the users' cellphone. 3. After the pager confirms the receiving status, it will automatically start the connection of BT 4.0 module and cellphone, and forward the Receive ACK to PS&DRT System through the Internet of cellphone to confirm that the message is received.	●	●	●
E12	Alert Buffering	1. Since the traditional voice pager provide the prompt tone playing of the message by using the feature of Analog' s call sending (The sending time length of 2-Tone Tone B), the users get used to distinguish the objects of dispatch or the mission type through the different tones. However, the Digital dispatch has not equipped with the same signal feature as the Analog. To reach the same Receive Alert function in the Digital system, we provide Alert Buffering function. 2. If the pager receives other voice calls during the process of playing a temporary-saved voice, it will shut down the currently playing voice message and notify the user with a short tone. Then, it will play the new voice message.	●	●	●

The logo features the text "G-1" in a large, bold, black serif font. The text is centered within a yellow rectangular area. To the left of the "G" is a small white circle with a horizontal line extending to the left. To the right of the "1" is a horizontal line with a series of small white squares below it. Above the "G-1" is a horizontal line with a small white square above it. Below the "G-1" is a horizontal line with a series of small white squares below it. The background is a solid yellow color.

G-1